



# Silo Loading System

We provide total solution to full fill the storage silo, using the stage of art in pneumatic conveying system

From all of the package source,

Such as Bulk Truck, Bulk Container, Tote Bin, IBC Bin, Big Bag & 25 kg Bag to Storage Silos

PP Pellet

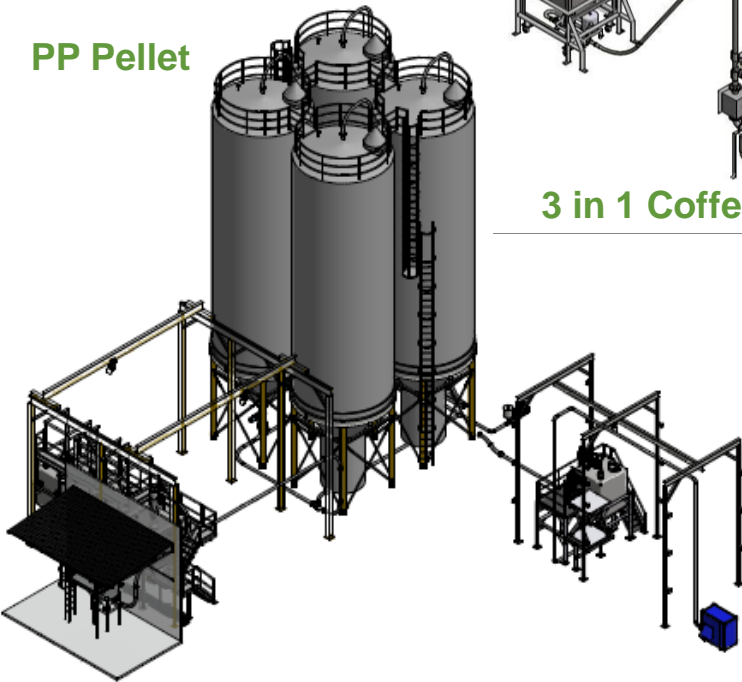

3 in 1 Coffee

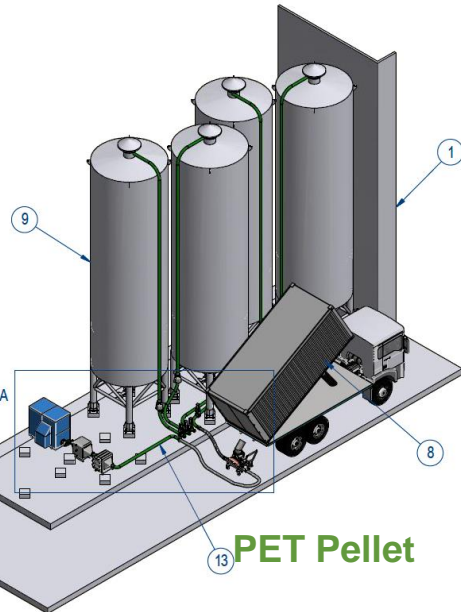
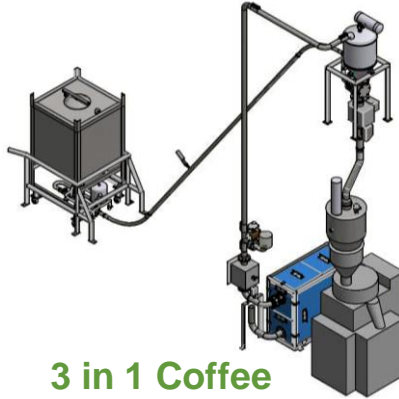

PET Pellet

Sugar Granule

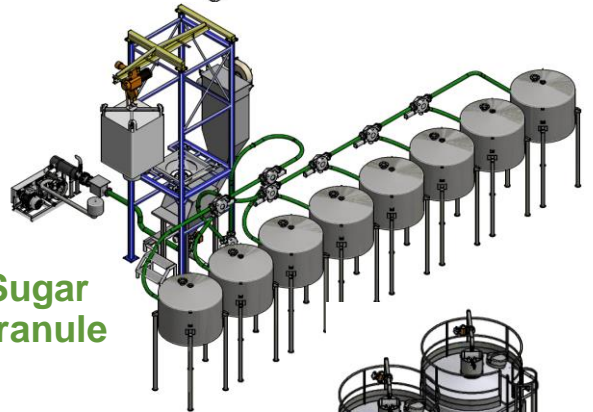

PVC resin & Calcium Carbonate Powder



Wheat Flour

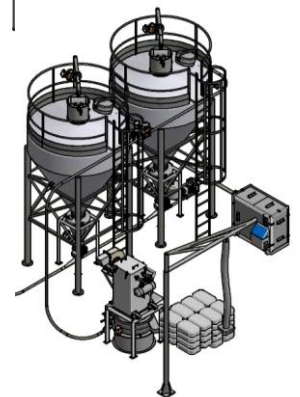



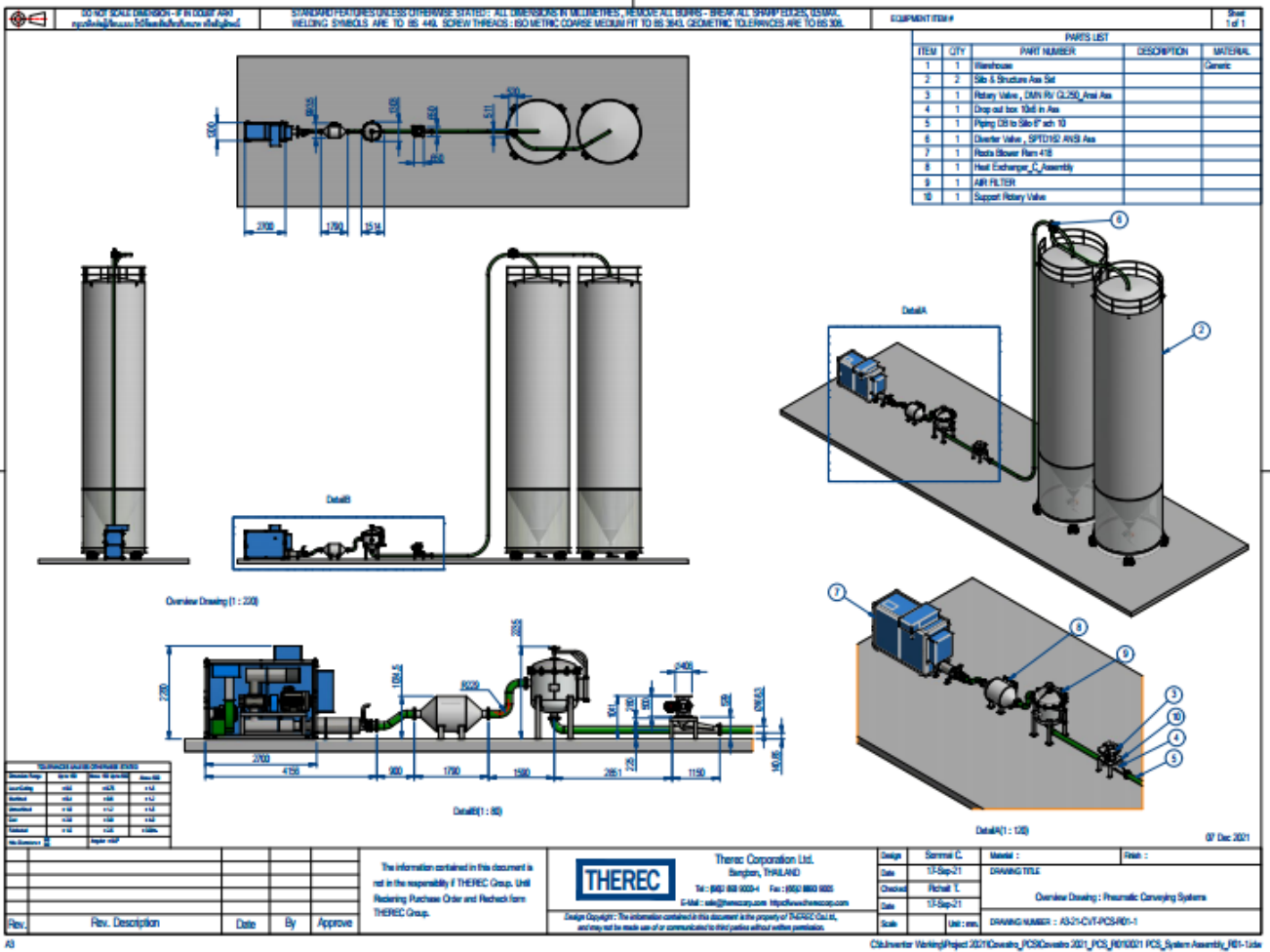

# Standard Design Silo Loading System

Bulk Material from Production Line, Big Bag or Small Bag



Roots Blower with Acoustic Enclosure



Water Cool Air Cooler



Rotary & Diverter Valve



Air Filter

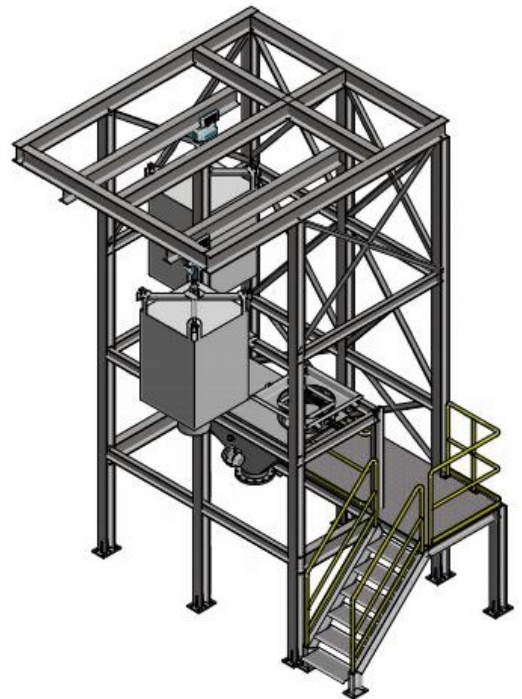

Big Bag Unloader





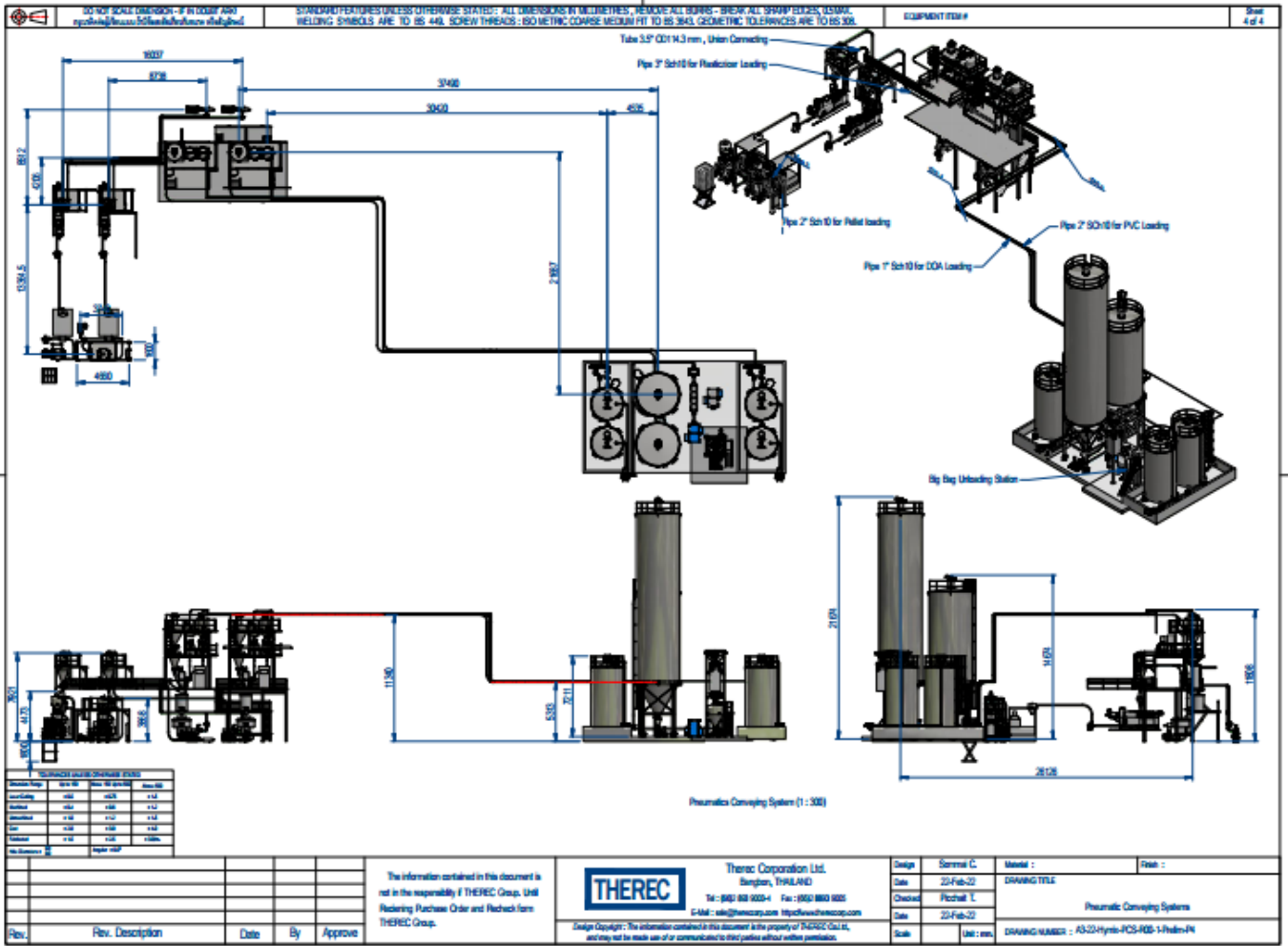

# Standard Design Silo Loading System

## Bulk Material from Bulk Truck (Tank Car)



100 m3 PVC Storage Silo  
 Load in by 16 Tons PVC Tank Car  
 Designed Operation time in 60 minute



Roots Blower with Acoustic Enclosure



Electrical Fan Cool Air Cooler & Air Filter



PVC Powder Silo loading & Weighting system / deliver from 16 tons bulk truck

## Silos loading system (PVC Resin powder) TPC (SCGC group)

The total system consisting of :

- 1 of 100.0 m<sup>3</sup> Stainless steel AISI304 Silos for PVC resin
- 1 of Truck blower for bulk truck to silos 50 kw
- 1 of Bag filters for dust controlling system
- 1 of Electrical control box, with SEMENS S7 1200 PLC with SIEMENS touch screen & SCADA system



VC3500



PVC Silo & DOA  
Storage tanks  
/weight monitoring  
system





# Therec Engineering & Consulting Co., Ltd.

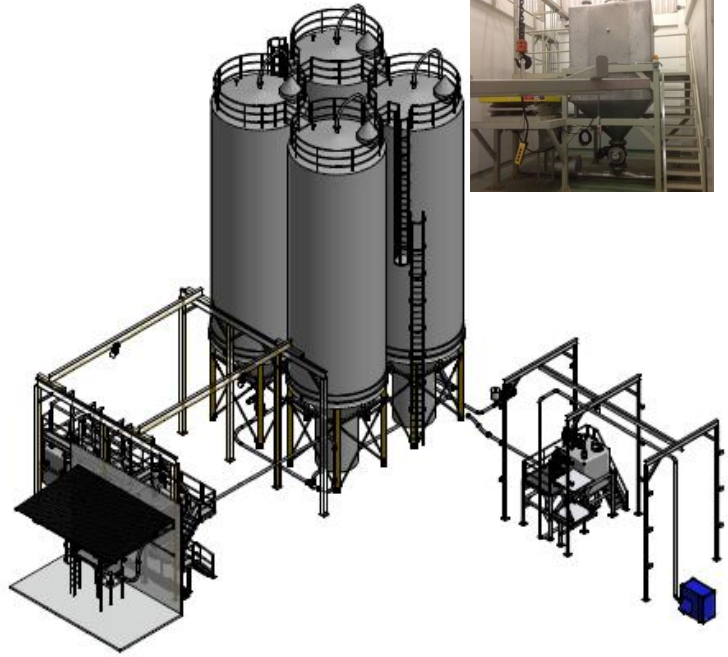

## Silos loading system (PE Pellet ) CNC International (CPPC group)

The total system consisting of :

- 1 of 5.0 tons Pneumatic conveying systems
- 1 of 1.0 tons Pneumatic conveying systems
- 1 of Big bag unloading stations, 1 rail, 1 hoist operated, 2,000 litre hopper
- 5 of Big bag unloading stations, 1 Overhead Crane operated, 6,000 litre hopper
- 1 of High pressure ring blower 7.5kw / 10.0 hp
- 1 of High pressure roots blower 37.0kw / 50.0 hp
- 1 of Heavy duty air lock rotary valves , Stainless steel 304 , 10.0 inches
- 4 of Medium duty air lock rotary valves , Stainless steel 304 , 6.0 inches
- 4 of 200 m<sup>3</sup> (100 tons) J&D Aluminium knock down silos
- 4 of 200 tons load cell set
- 1 of Electrical control box, with SIEMENS LOGO PLC



# Therec Engineering & Consulting Co., Ltd.

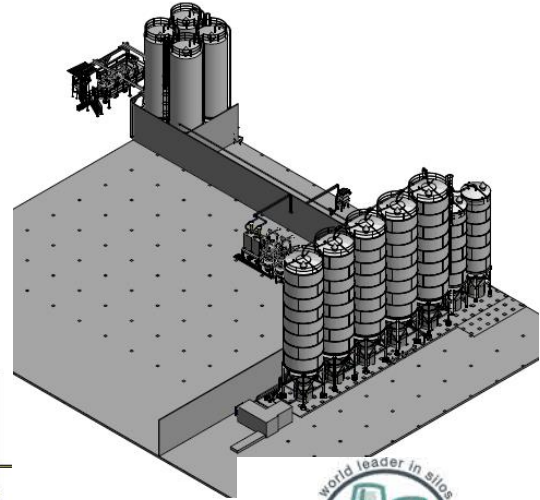

**Silos loading system (PP&PE Pellet ) Fitesa CNC (CPPC group)**



**Silos Feeding Pipe & Valves Set**



# Therec Engineering & Consulting Co., Ltd.



## PP & PE Pellet reception system (PP&PE Pellet ) Fitesa CNC (CPPC group)

The total system consisting of :

- 2 of 4.5 tons Pneumatic conveying systems
- 2 of Big bag unloading stations,1 hoist operated, 2,000 litre hopper
- 1 of Big bag unloading stations, 1 hoist operated, 6 ports drop out box
- 5 of 400 m<sup>3</sup> (200 tons) J&D Aluminium knock down silos
- 2 of 160 m<sup>3</sup> (80 tons) J&D Aluminium knock down silos
- 5 of 200 tons load cell set / Thames side sensor
- 5 of 80 tons load cell set / Thames side sensor
- 1 of 6.5 tons/hr Auto debagging machine from LaborSave



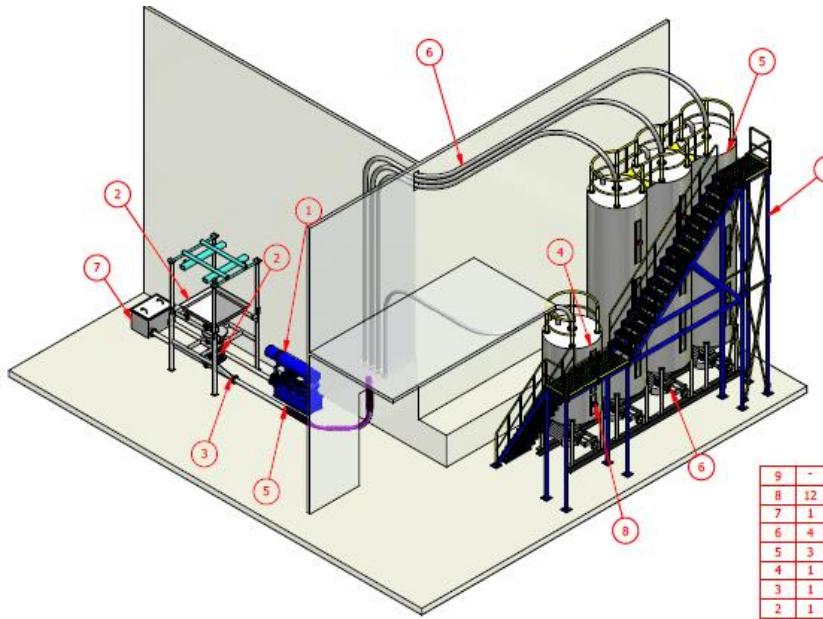

9	-
8	12
7	1
6	4
5	3
4	1
3	1
2	1
1	1

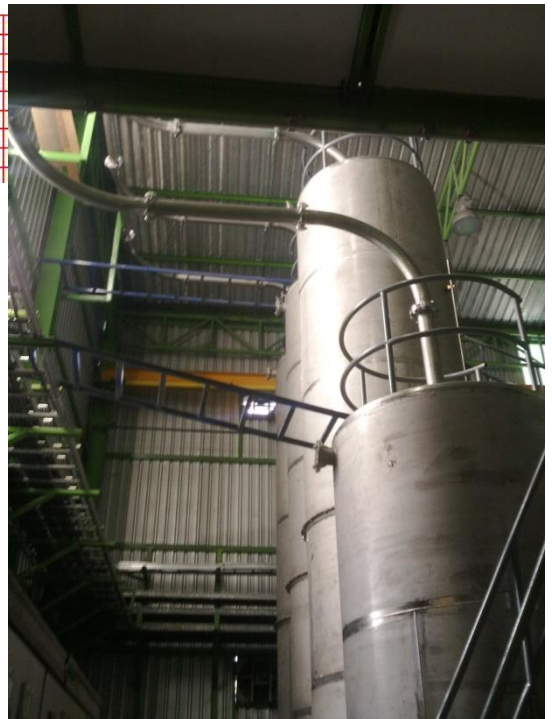

## Sea Bulk loading system (PE Pellet ) SCG Chem (TPC) Warehouse

The total system consisting of :

- 1 of 7.0 tons Pneumatic conveying systems
- 1 of Big bag unloading stations, fork lift operated, 50 litre hopper
- 1 of High pressure Roots blower 18.5 kw / 25.0 hp
- 1 of Bag filters for dust controlling system, with 1,300 m<sup>3</sup> centrifugal fan
- 1 of 4.0 m<sup>3</sup> Stainless steel silos
- 3 of 8.0 m<sup>3</sup> Stainless steel silos
- 1 of Heavy duty air lock rotary valves (powder valve), Stainless steel 304
- 1 of Electrical control box, with SIEMENS LOGO PLC



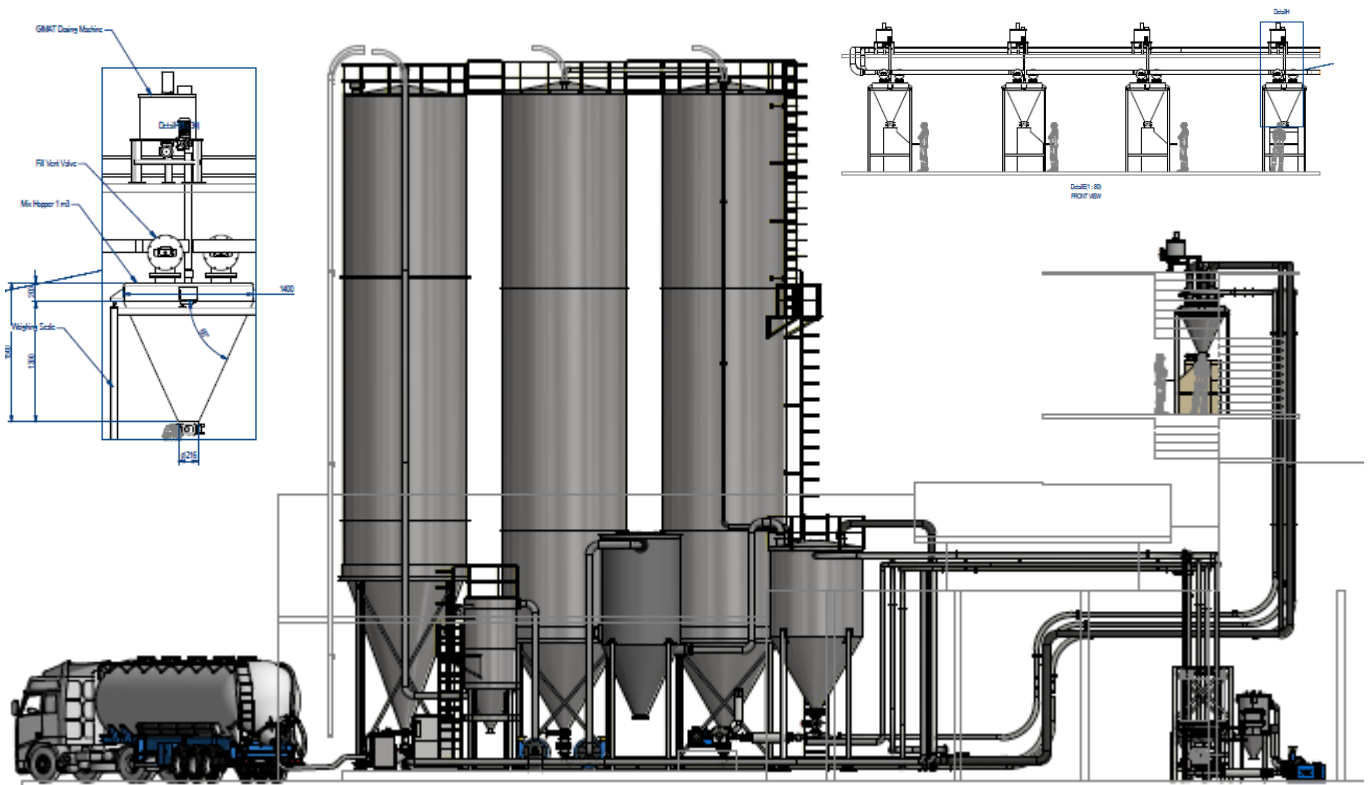

## Silos Weighting system (PVC powder & Calcium Carbonate Powder ) Saha Area , Twin Lion brand PVC pipe factory

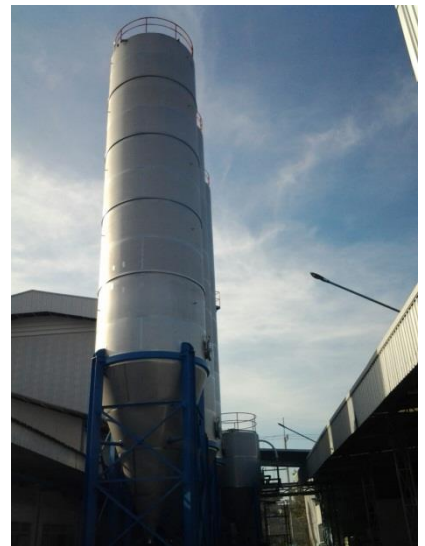

The total system consisting of :

- 3 of 200 m<sup>3</sup> (100 tons) Stainless Steel 304 silos
- 1 of 20 m<sup>3</sup> (12 tons) Stainless Steel 304 silos
- 4 of 200 tons load cell sets, Thames Sides Sensor , Smart Indicator , Junction box and Low profile mounting load cell assemble set
- 4 of 1.0 m<sup>3</sup> (350 kg) Stainless Steel 304 silos
- 4 of 1200 kg load cell sets, Thames Sides Sensor , Smart Indicator , Junction box and Lever mount loadcell weighting assembly
- 12 of Scale valves size 4.0"
- 1 of Electrical control box, with SIEMENS S7 1200

# Therec Engineering & Consulting Co., Ltd.

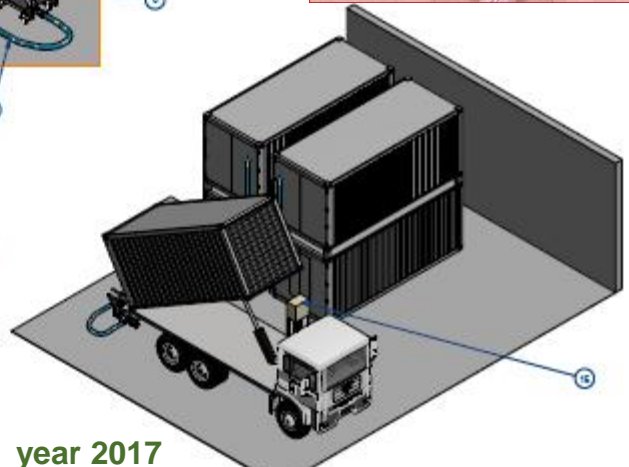
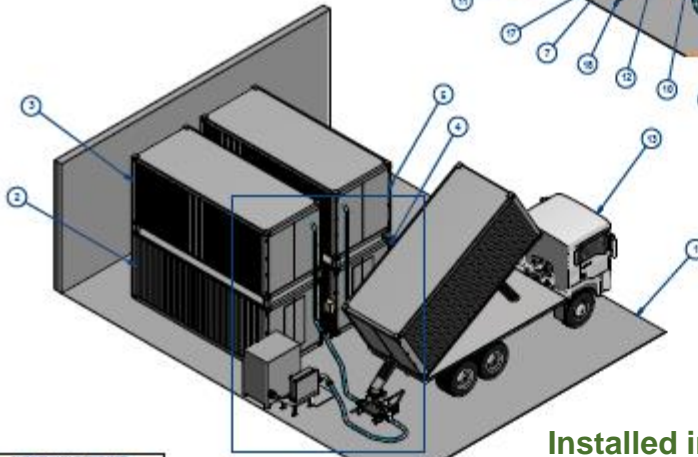
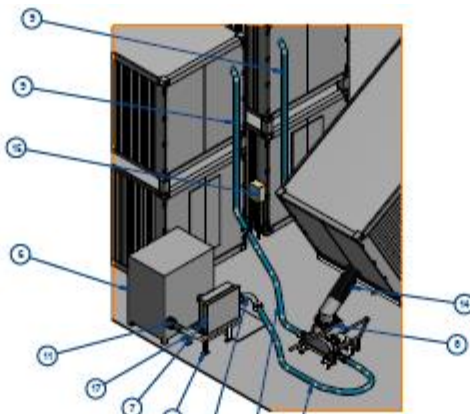

Installed in year 2017



## Container Unloading system (PE Pellet) Grand siam composi / Aeroklas

The total system consisting of :

- 4 of 20 tons Carbon Steel container, for storage
- 1 of 30 kw roots blower with acoustic enclosure
- 1 of 18 tons/hr Pneumatic conveying systems
- 1 of Heavy duty feeding rotary valves (pellet valve), Stainless steel
- 1 of Air to Air unit air cooler



# Bulk Material Handling System Integrator

## Silos System Component



Silo Vent Bag filter

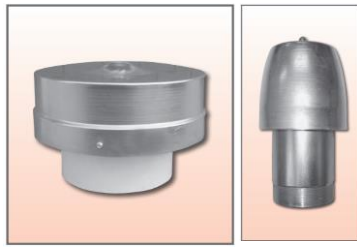

Silo & Tank Safety Valve



Solo Slide gate valve



Silo Loading Bellow



MIX s.r.l.  
MIXING SYSTEMS AND  
COMPONENTS FOR PLANTS

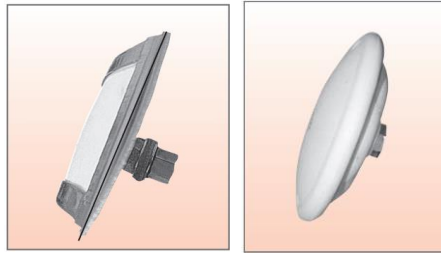

Silo Aeration (Fluidized) Pad & Disc



Silo Dust Explosion Protection panel



Silo Loading & Unloading Rotary & Diverter Valve



Silo Loading Pipe, Long Radius Bend, Coupling & Flexible Hose



Air Knocker



Silo Level sensor



Silo Low profile mounting Shear Beam load cell



Silo Low profile mounting Pan Cake load cell



Silo mount ,Atex & IECEx Certification



Silo Loading Blower



Smart Digital Display



Junction box



**Therec Engineering & Consulting Co, Ltd.** [www.thereceng.com](http://www.thereceng.com)

Tel (662) 893 9003-4 (5 lines)

Fax : (662) 893 9005 ,893 9178

88 Soi Karnjanapisek 4/2 Karnjanapisek Rd. Bangbon Bangkok 10150 Thailand

General product Therec 01 / 2016

บริษัท เทรค เอ็นจิเนียริ่ง แอนด์ คอนซัลติง จำกัด

THEREC ENGINEERING & CONSULTING CO.,LTD.