

THEREC ENGINEERING & CONSULTING CO.,LTD.

THEREC PROCESSING MACHINE CO.,LTD

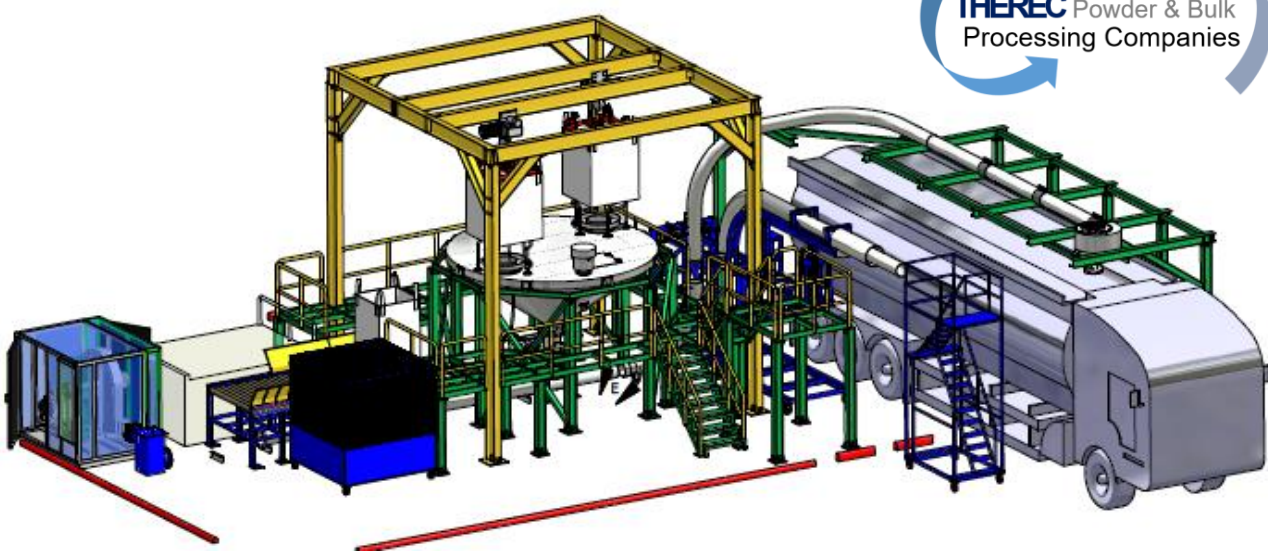

Full Bulk material handling system for powder and bulk processing line / Storage / Loading / Unloading / Weighing / Mixing / Sizes classifying Connecting all together by pneumatic conveying system and control.

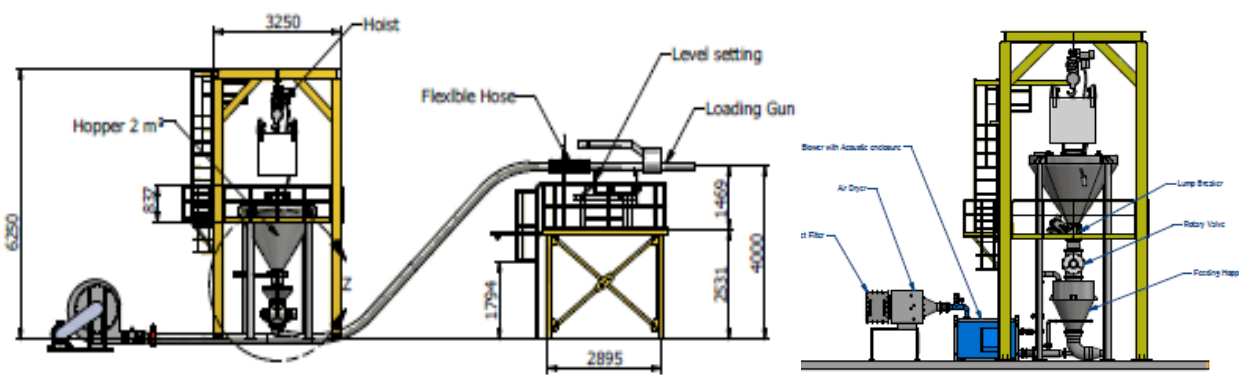

Sea bulk Loader or Bulk Truck loader / Mobile or Fixed Station

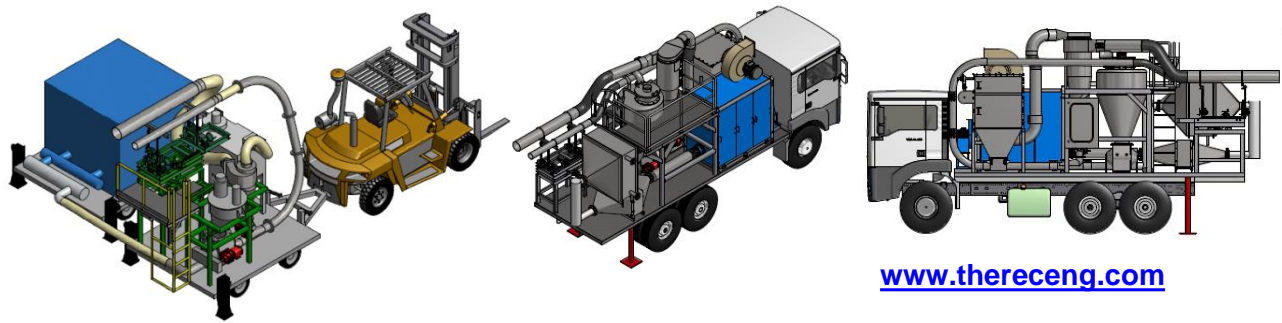

Bulk Material Handling System Integrator

Silos System Component



Silo feeding Multi ways diverter valve



Silo pressure & vacuum valve



DMN WESTINGHOUSE
Rotary, Diverter & Scale valve



GVF components



Cast iron and Stainless steel Slide gate valve



Vibrofluidizer



Fluidification plate PF & FLUO



Level sensor



Air Knocker



Flame Arrester



VIGILEX
Bursting panel



STIF



Jansen & Heuning
bulk handling systems



THEREC
THEREC PROCESSING & CONSULTING CO., LTD.



Silo Vent Bag filter



MORRIS
COUPLING COMPANY



Silo Loading Bellow



Long Bend & Coupling



Roots
Silo Feeding Blower



Low profile mounting assembly



Install and Removal without lifting tool



Silo mount ,Atex & IECEx Certification



Smart Digital Display



Junction box

Therec Engineering & Consulting Co, Ltd. www.thereceng.com
 Tel (662) 893 9003-4 (5 lines) Fax : (662) 893 9005 ,893 9178
 88 Soi Karnjanapisek 4/2 Karnjanapisek Rd. Bangbon Bangkok 10150
 Thailand
 General product Therec 01 / 2016



Thames Side

บริษัท เทอร์เควค ไซน์อีเนจียริง แอนด์ คอนซัลติง จำกัด

THEREC
THEREC ENGINEERING & CONSULTING CO.,LTD.

[CONTAINER LOADERS]

Loading shipping containers at 90 degrees enables companies to fill 100% of a container's volume, therefore optimizing freight efficiency. Shipping containers can be inserted either directly with a standard trailer or from above with a forklift, crane or reach stacker.

OTHER BENEFITS:

- Speed up the container loading process.
- Reduce labor.
- Weight the container during loading.
- Maximize operator safety.



A-WARD™



COFFEE



Kraft Foods in France uses an A-Ward container loader to load coffee beans into shipping containers for domestic storage.

PLASTIC GRANULES



Coca-Cola, Tetra-Pak, Indorama, Abu Dhabi Polymers and Bumi Mulia all use A-Ward container unloaders to unload polymers.

[CONTAINER UNLOADERS]

A-Ward container unloaders enable immediate and controlled unloading of shipping containers and remove the reliance on expensive and scarce tilting trailers. Shipping containers can be inserted either directly with a standard trailer or from above with a forklift crane or reach stacker.

OTHER BENEFITS:

- Maximize operator safety.
- Reduce labor.
- Control unloading speed by adjusting tilt angle.
- Ability to unload over a longer period of time.



A-WARD™



Therec Engineering & Consulting Co., Ltd.



First Installed in Site 1 / year 2007



Move to Site 10 / year 20015

Sea Bulk loading system (PE Pellet) SCG Chem (TPE)
Warehouse Site 1 / and Finally moved to Site 10

The total system consisting of :

- 1 of 11.0 tons Pneumatic conveying systems
- 1 of Big bag unloading stations, gravity feed with 1,000 litre hopper
- 1 of Fixed feeding gun for container truck, 4 directions and swing
- 1 of High pressure Centrifugal blower 15.0 kw / 20.0 hp
- 1 of Heavy duty air lock granular rotary valves (pellet valve),
Stainless steel 304
- 1 of Electrical control box, with SIEMENS LOGO PLC



Therec Engineering & Consulting Co., Ltd.

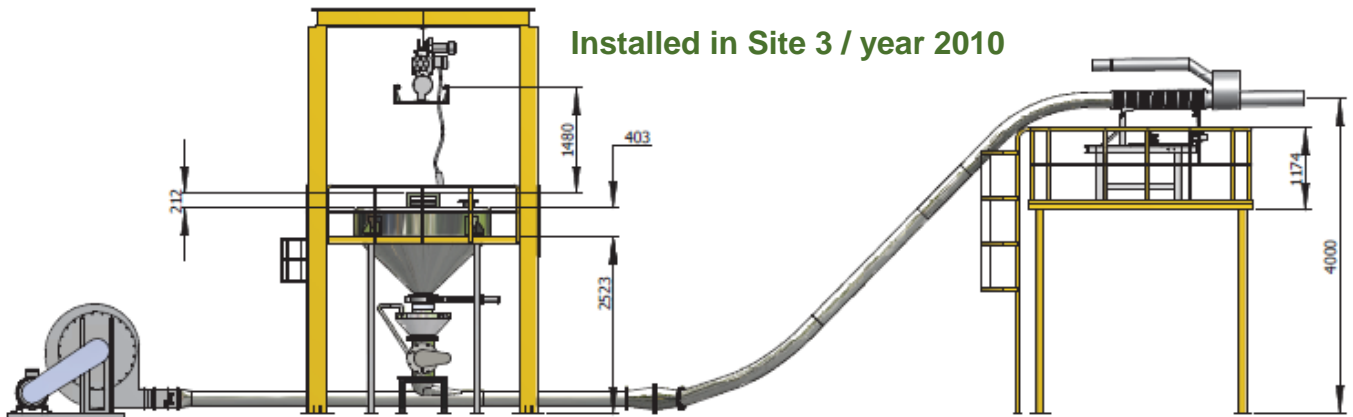

Sea Bulk loading system (PE Pellet) SCG Chem (TPE) Warehouse Site 3

The total system consisting of :

- 1 of 25.0 tons Pneumatic conveying systems
- 1 of Big bag unloading stations, 1 rail, 2 hoist operated, 3,000 litre hopper
- 1 of Fixed feeding gun for container truck, 4 directions and swing
- 1 of High pressure Centrifugal blower 22.0 kw / 30.0 hp
- 1 of Heavy duty air lock granular rotary valves (pellet valve),
Stainless steel 304
- 1 of Electrical control box, with SIEMENS LOGO PLC



Therec Engineering & Consulting Co., Ltd.



Roots blower package with air cooler set



Schenck Accurate Mass Flow Meter set

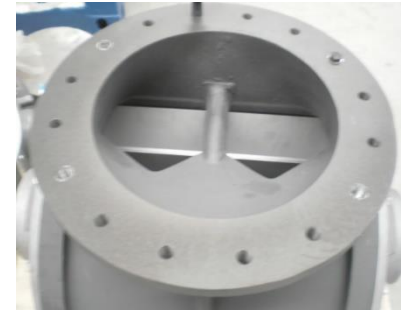

Non cutting Rotary valve (Granular Valve)

Installed in Site 7 / year 2012

The total system consisting of :

- 1 of 35.0 tons/hr Pneumatic conveying systems
- 1 of Pipe set, gravity feed with 1,000 litre hopper
- 1 of Adjustable feeding gun for container truck, 4 directions and swing
- 1 of High pressure Roos blower 45.0 kw / 60.0 hp
- 1 of Heavy duty air lock granular rotary valves (pellet valve),
Stainless steel 304
- 1 of Electrical control box, with SIEMENS
S7 300 PLC

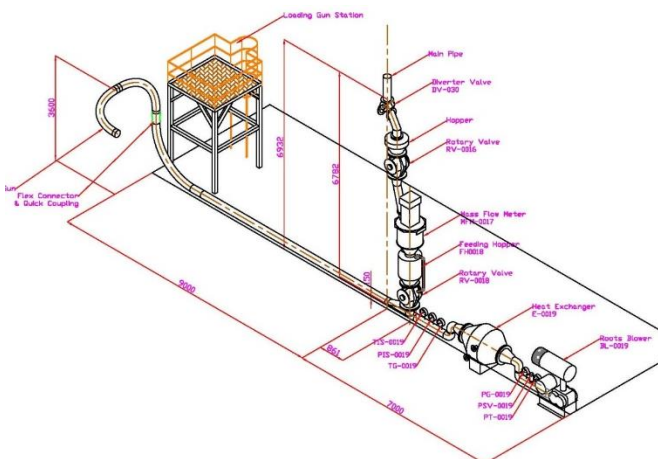

Sea Bulk loading system (PE Pellet) SCG Chem (TPE)
Warehouse Site 7



Therec Engineering & Consulting Co., Ltd.

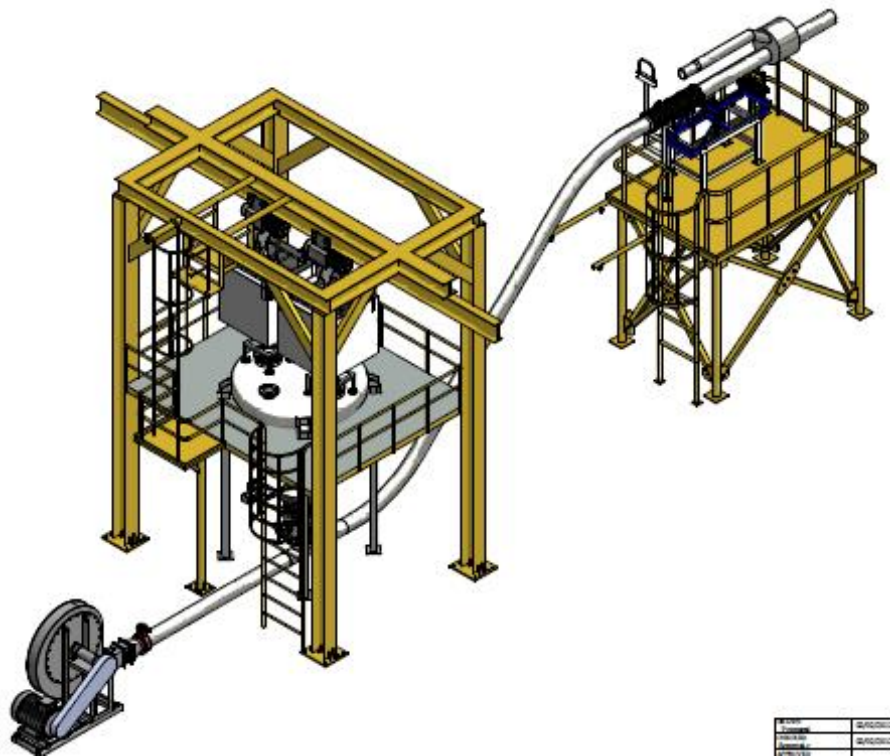

First Installed in Site 1 / year 2014



Sea Bulk loading system (PE Pellet) SCG Chem (TPE) Warehouse Site 5

The total system consisting of :

- 1 of 20.0 tons Pneumatic conveying systems
- 1 of Big bag unloading stations, 1 rail, 2 hoist operated, 3,000 litre hopper
- 1 of Fixed feeding gun for container truck, 4 directions and swing
- 1 of High pressure Centrifugal blower 18.5 kw / 25.0 hp
- 1 of Heavy duty air lock granular rotary valves (pellet valve), Stainless steel 304
- 1 of Electrical control box, with SIEMENS LOGO PLC



Installed in year 2014

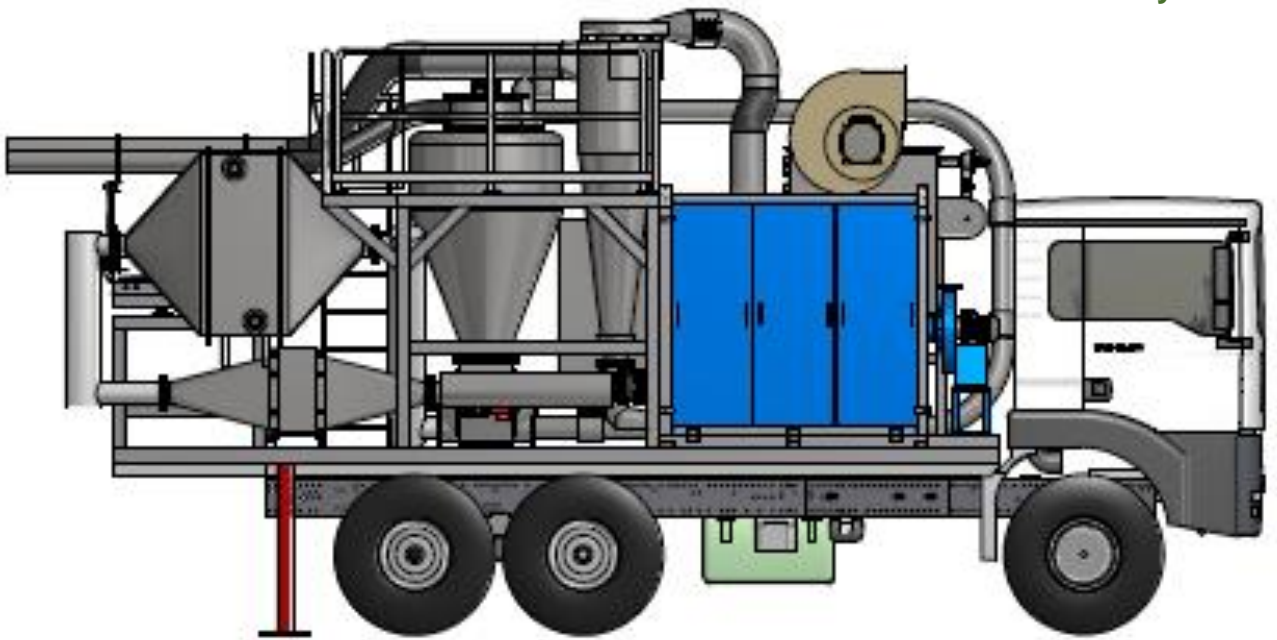

Sea Bulk loading system (PVC Powder) SCG Chem (TPC) Warehouse , Site 9

The total system consisting of :

- 1 of 18.0 tons Pneumatic conveying systems
- 1 of Fixed feeding gun for container truck, 4 directions and swing
- 1 of High pressure Roots blower 37kw / 50.0 hp
- 1 of Cyclone for dust controlling system, with 1,300 m³ centrifugal fan
- 1 of Bag filters for dust controlling system, with 1,300 m³ centrifugal fan
- 2 of Heavy duty air lock rotary valves (powder valve), Stainless steel 304
- 1 Stainless steel air cooler , air to water (cooling tower water) type
- 1 Stainless steel housing in line air filter , HEPA element
- 1 of Electrical control box, with SIEMENS LOGO PLC

Therec Engineering & Consulting Co., Ltd.

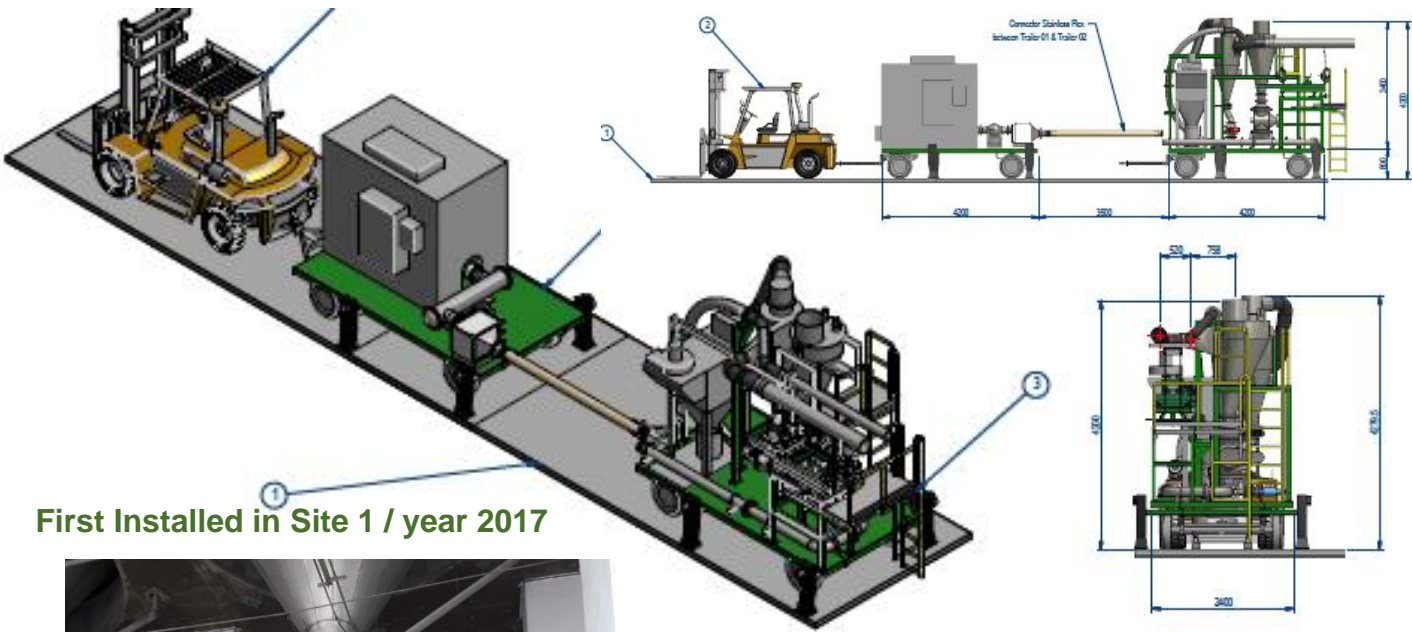

First Installed in Site 1 / year 2017

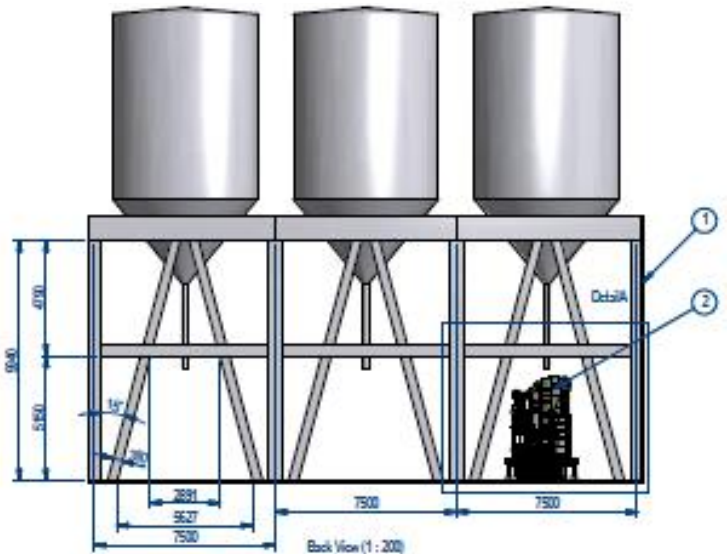

Sea Bulk loading system (PVC Powder) SCG Chem (TPC) Warehouse, Site 9

The total system consisting of :

- 1 of 18.0 tons Pneumatic conveying systems
- 1 of Fixed feeding gun for container truck, 4 directions and swing
- 1 of High pressure Roots blower 45kw / 60.0 hp
- 1 of Cyclone for dust controlling system, with 1,300 m³ centrifugal fan
- 1 of Bag filters for dust controlling system, with 1,300 m³ centrifugal fan
- 2 of Heavy duty air lock rotary valves (powder valve), Stainless steel 304
- 1 Carbon steel air cooler , air to water (cooling tower water) type
- 1 Stainless steel housing in line air filter , Mini pleat element
- 1 of Electrical control box, with Mitsubishi PLC



Therec Engineering & Consulting Co., Ltd.



Installed in year 2014



Sea Bulk loading system (PE Pellet) PTT PL Warehouse

The total system consisting of :

- 1 of 18.0 tons Pneumatic conveying systems
- 1 of Big bag unloading stations, over head crane operated, 1,500 litre hopper
- 1 of Small bag dumping stations, manual operated, 100 litre hopper
- 1 of Moveable feeding gun for container truck, 4 directions and swing
- 1 of High pressure air compressor 75.0 kw / 100.0 hp
- 2 of Heavy duty air lock rotary valves (powder valve), Stainless steel 304
- 1 of Electrical control box, with SIEMENS LOGO PLC



Therec Engineering & Consulting Co., Ltd.



Sea Bulk loading system (PE Pellet) SMC Logistic Warehouse

The total system consisting of :

- 1 of 18.0 tons Pneumatic conveying systems
- 1 of Big bag unloading stations, Fork lift crane operated, 1,000 liter hopper
- 1 of Moveable feeding gun for container truck, 4 directions and swing
- 1 of High pressure air compressor 37.0 kw / 50.0 hp
- 2 of Heavy duty mobilized set air lock rotary valves (powder valve), Stainle 304
- 1 of Electrical control box, with SIEMENS LOGO PLC



Installed in year 2011

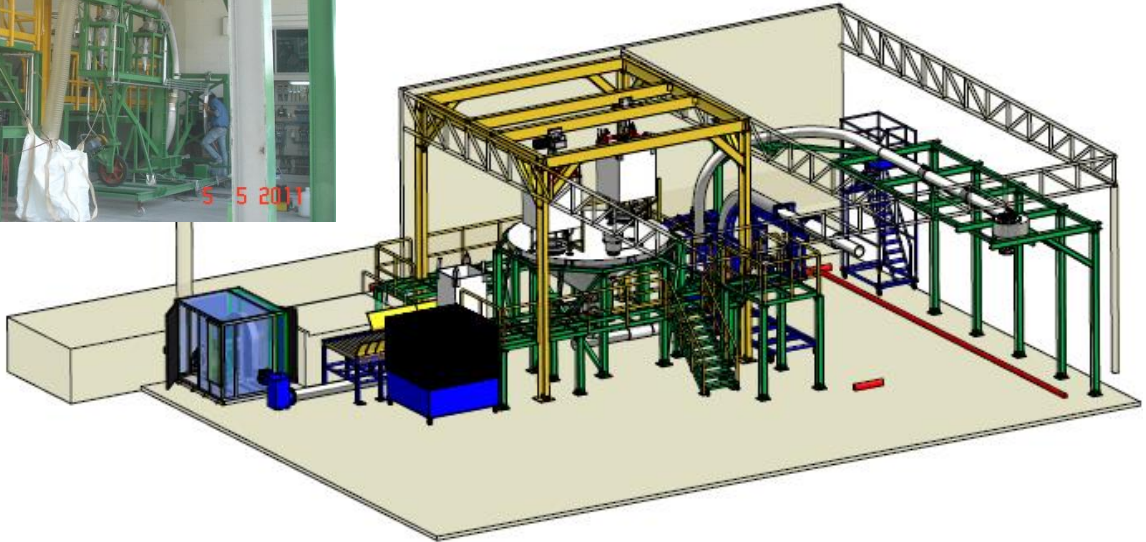

Sea Bulk loading system (PE Pellet) Ptt Global Chem Warehouse

The total system consisting of :

- 1 of 25.0 tons Pneumatic conveying systems
- 3 of Automatic roller conveyors for bulk bag feeding
- 1 of Big bag unloading stations, 2 rails, 2 hoists operated, 4,000 litre hopper
- 1 of Moveable feeding gun for container truck, 4 directions and swing
- 1 of Feeding pipe, Loading cyclone and Loading bellow for Bulk truck
- 1 of High pressure Centrifugal blower 30 .0kw / 40.0 hp
- 1 of Heavy duty air lock granular rotary valves (pellet valve), Stainless steel 304
- 2 of Bag filters for dust controlling system, with 3,500 m³ centrifugal fan
- 1 of Electrical control box, with SIEMENS S7 300 PLC with PROFACE touch screen , suitable for full automatic operation and SCADA system requirement

Therec Engineering & Consulting Co., Ltd.

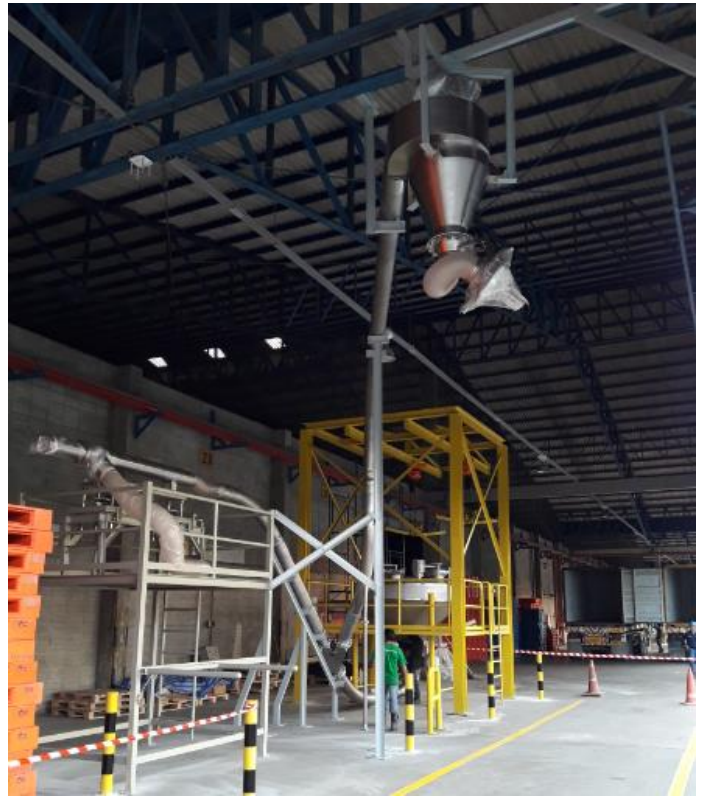

Sea Bulk loading system (PE Pellet) SMC Logistic, Warehouse 2

The total system consisting of :

- 1 of 20.0 tons Pneumatic conveying systems
- 1 of Big bag unloading stations, 2 rails, 2 hoists operated, 3,000 litre hopper
- 1 of Moveable feeding gun for container truck, 2 directions and swing
- 1 of Feeding pipe, Loading cyclone and Loading bellow for Bulk truck
- 1 of High pressure Centrifugal blower 18.5 kw / 25.0 hp
- 1 of Heavy duty air lock granular rotary valves (pellet valve), Stainless steel 304
- 1 of Flap type diverter valve size 8.0 inches, manual version
- 1 of Electrical control box, with SIEMENS LOGO PLC



Therec Engineering & Consulting Co., Ltd.

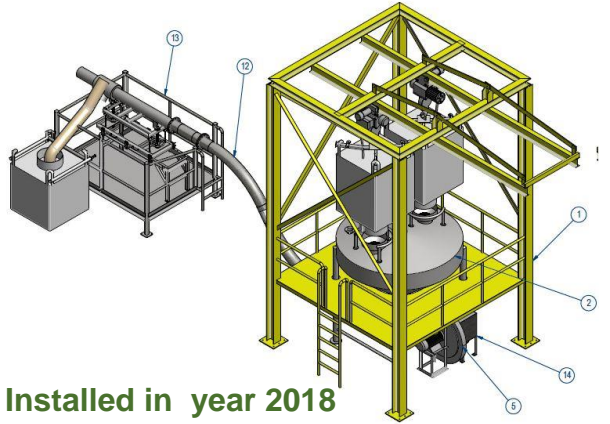

Installed in year 2018



Sea Bulk loading system (PE Pellet) SMC Logistic, Warehouse 2

The total system consisting of :

- 1 of 18.0 tons Pneumatic conveying systems
- 1 of Big bag unloading stations, 2 rails, 2 hoists operated, 4,000 litre hopper
- 1 of Moveable feeding gun for container truck, 2 directions and swing
- 1 of Feeding pipe
- 1 of High pressure Centrifugal blower 18.5 kw / 25.0 hp
- 1 of Heavy duty air lock granular rotary valves (pellet valve), Stainless steel 304
- 1 of Flap type diverter valve size 8.0 inches, manual version
- 1 of Electrical control box, with SIEMENS LOGO PLC



Installed in year 2021

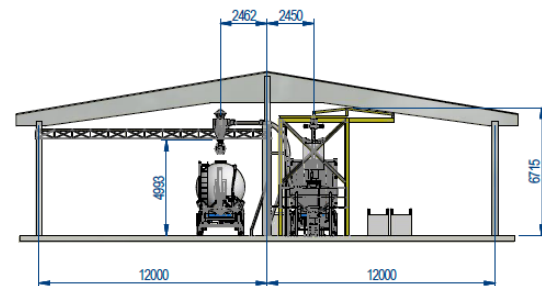
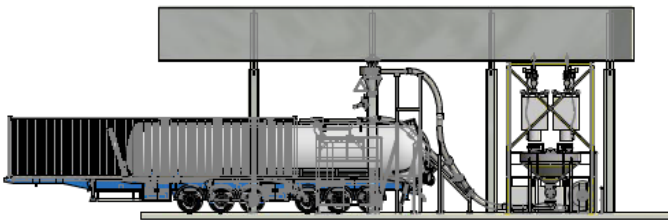
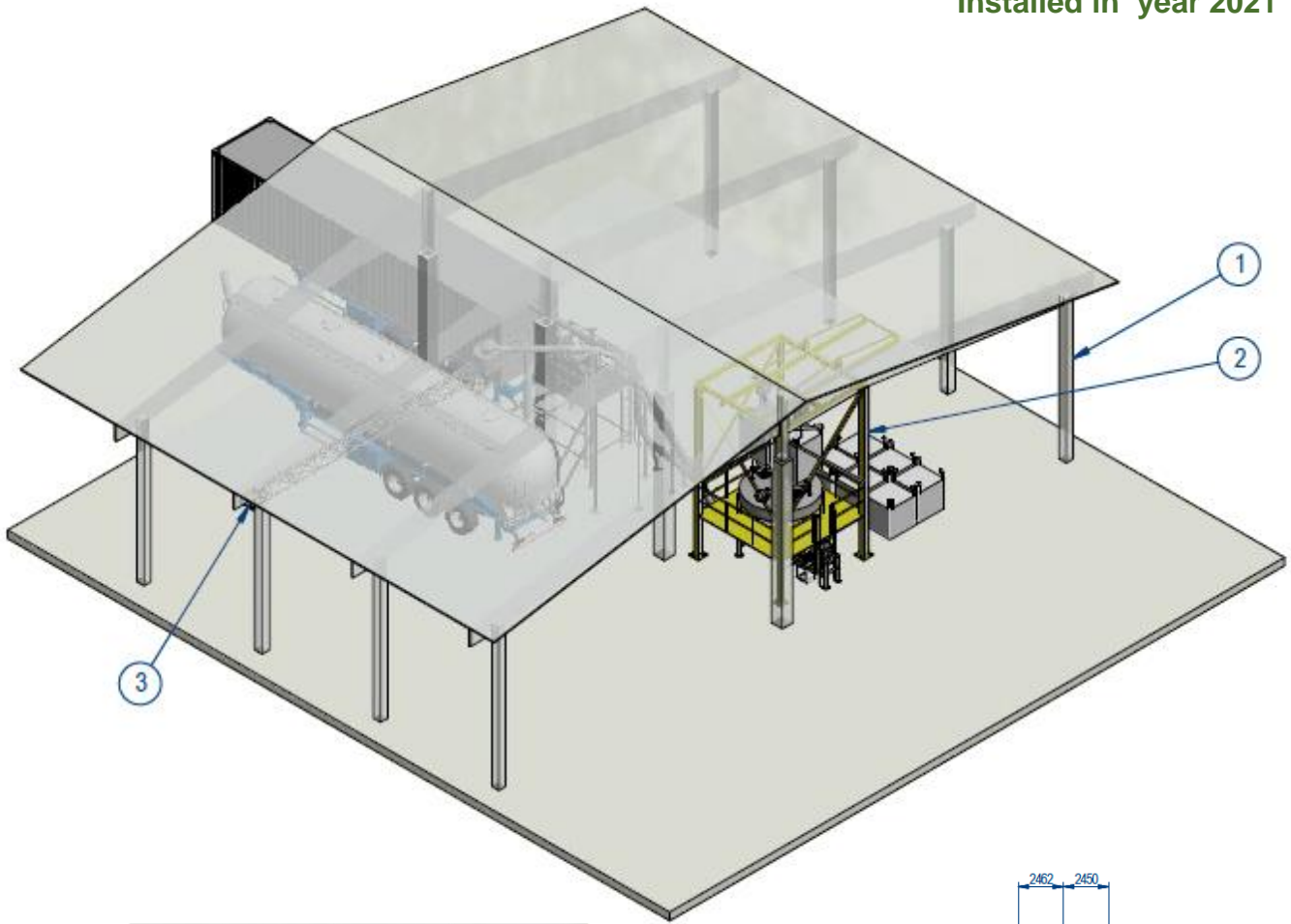

Sea Bulk loading system (PE Pellet) SMC Logistic, Warehouse 1

The total system consisting of :

- 1 of 18.0 tons Pneumatic conveying systems
- 1 of Big bag unloading stations, 2 rails, 2 hoists operated, 3,000 litre hopper
- 1 of Moveable feeding gun for container truck, 2 directions and swing
- 1 of Feeding pipe, Loading cyclone and Loading bellow for Bulk truck
- 1 of High pressure Centrifugal blower 18.5 kw / 25.0 hp
- 1 of Heavy duty air lock granular rotary valves (pellet valve), Stainless steel 304
- 1 of Flap type diverter valve size 8.0 inches, manual version
- 1 of Electrical control box, with SIEMENS LOGO PLC

Therec Engineering & Consulting Co., Ltd.

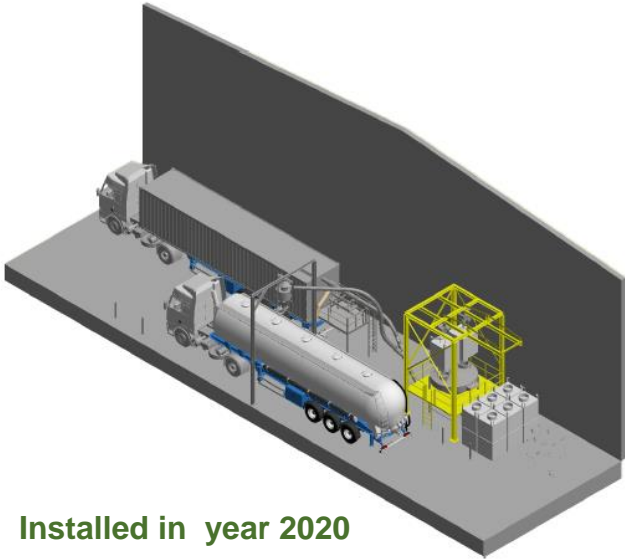

Installed in year 2020



Sea Bulk loading system (PE Pellet) SMC Logistic, Warehouse 1

The total system consisting of :

- 1 of 20.0 tons Pneumatic conveying systems
- 1 of Big bag unloading stations, 2 rails, 2 hoists operated, 3,000 litre hopper
- 1 of Moveable feeding gun for container truck, 2 directions and swing
- 1 of Feeding pipe, Loading cyclone and Loading bellow for Bulk truck
- 1 of High pressure Centrifugal blower 18.5 kw / 25.0 hp
- 1 of Heavy duty air lock granular rotary valves (pellet valve), Stainless steel 304
- 1 of Flap type diverter valve size 8.0 inches, manual version
- 1 of Electrical control box, with SIEMENS LOGO PLC



Therec Engineering & Consulting Co., Ltd.

Installed in year 2015

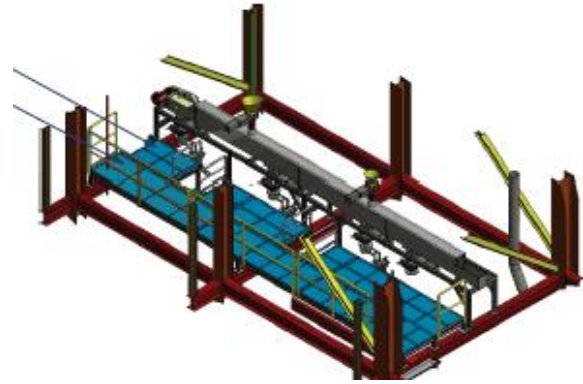
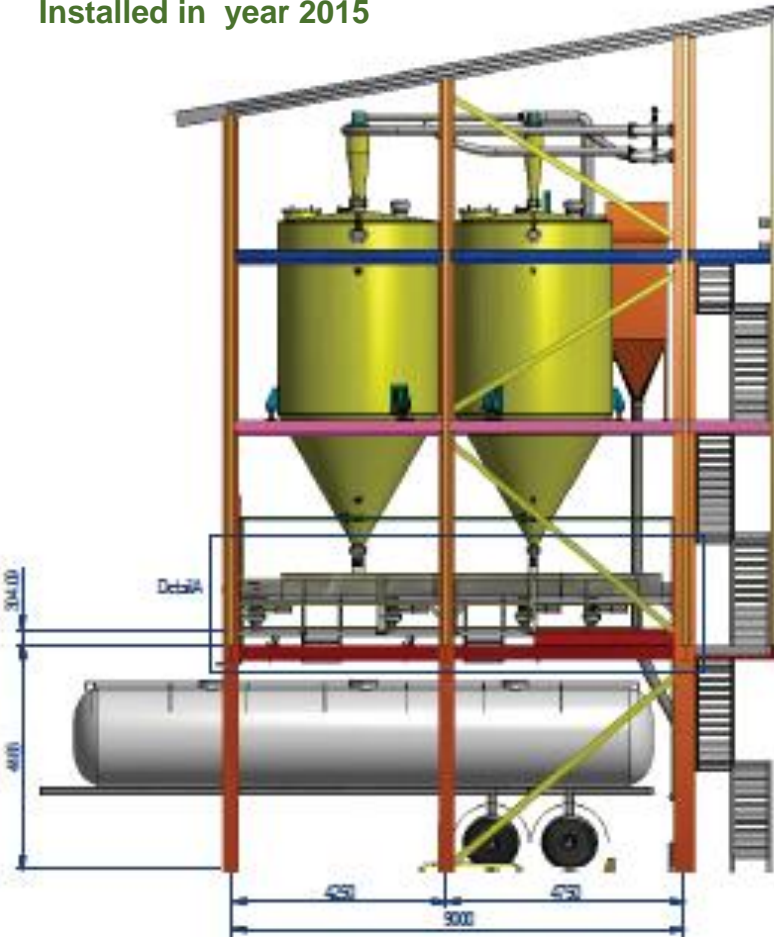

NESCAFE
SCREW FEEDER
SIZE 250

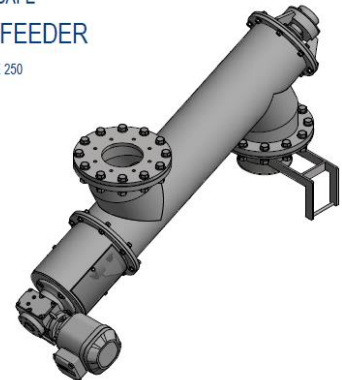

Bulk Truck loading system (Green Coffee) Quality coffee (Nest Café)

The total system consisting of :

- 2 of 38 m³ Carbon Steel silos, with Nitrogen purge system & plate form structure
- 1 of Load cell system set and automatic hanging load cell calibrating set
- 1 of 5.0 tons Pneumatic conveying systems
- 2 of Bag filters for dust controlling system, with 1,500 m³ centrifugal fan
- 1 of Big bag filling stations with load cell
- 1 of Chain conveyor set for bulk truck loading
- 4 of Magnetic separator sets
- 4 of Light duty feeding rotary valves (pellet valve), Stainless steel 316
- 1 of Heavy duty screw conveyor, Stainless steel 316
- 4 of Loading bellow with level sensor, Stainless steel 316





Installed in year 2015

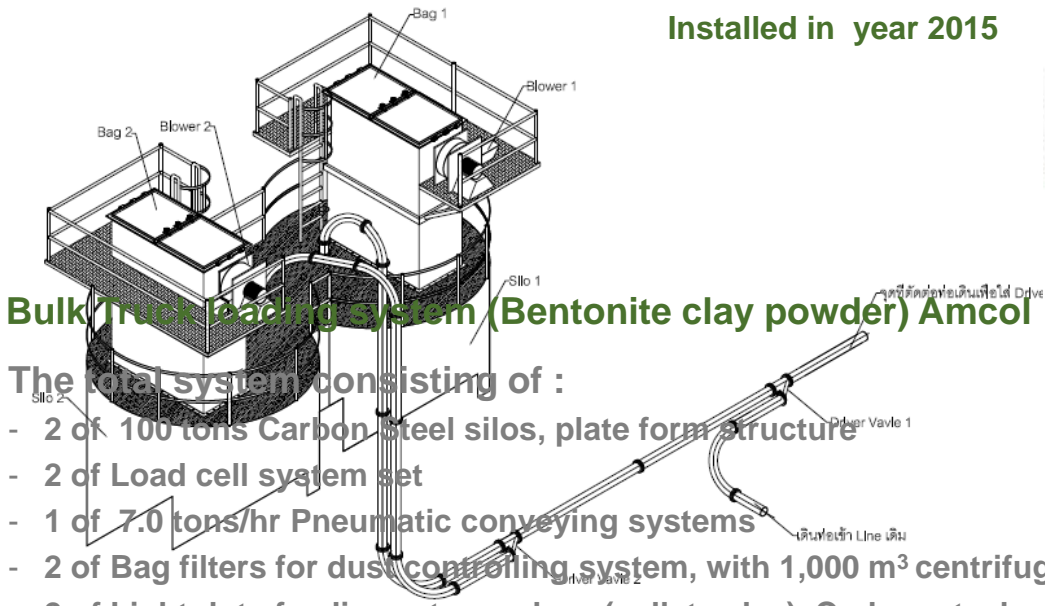

Bulk Truck loading system (Bentonite clay powder) Amcol

The total system consisting of :

- 2 of 100 tons Carbon steel silos, plate form structure
- 2 of Load cell system set
- 1 of 7.0 tons/hr Pneumatic conveying systems
- 2 of Bag filters for dust controlling system, with 1,000 m³ centrifugal fan
- 2 of Light duty feeding rotary valves (pellet valve), Carbon steel
- 2 of Loading bellow with level sensor, Carbon steel J&H

Therec Engineering & Consulting Co., Ltd.

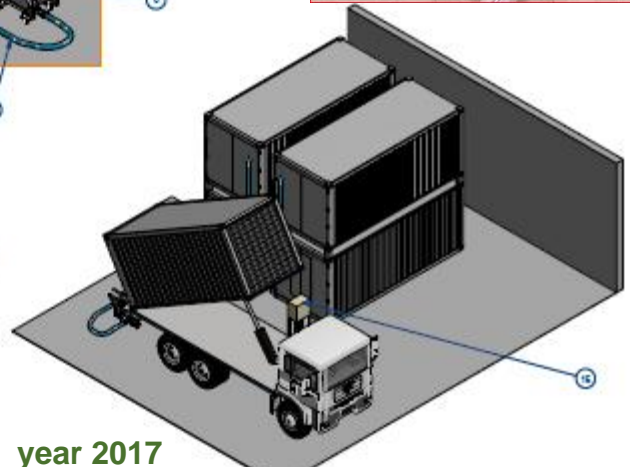
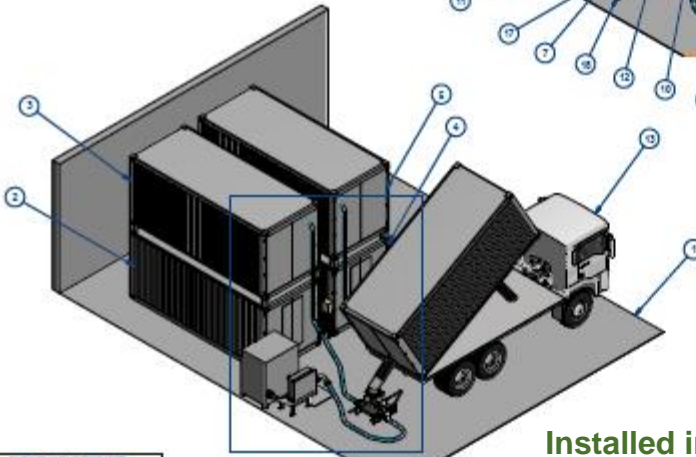
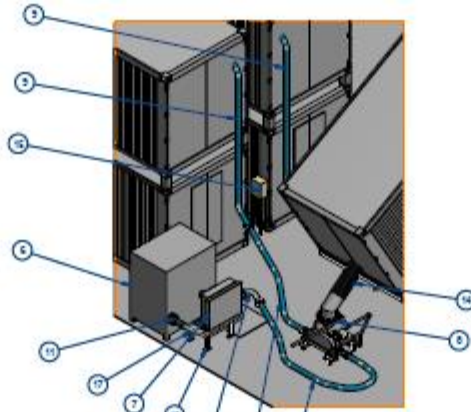

Installed in year 2017



Container Unloading system (PE Pellet) Grand siam composi / Aeroklas

The total system consisting of :

- 4 of 20 tons Carbon Steel container, for storage
- 1 of 30 kw roots blower with acoustic enclosure
- 1 of 18 tons/hr Pneumatic conveying systems
- 1 of Heavy duty feeding rotary valves (pellet valve), Stainless steel
- 1 of Air to Air unit air cooler



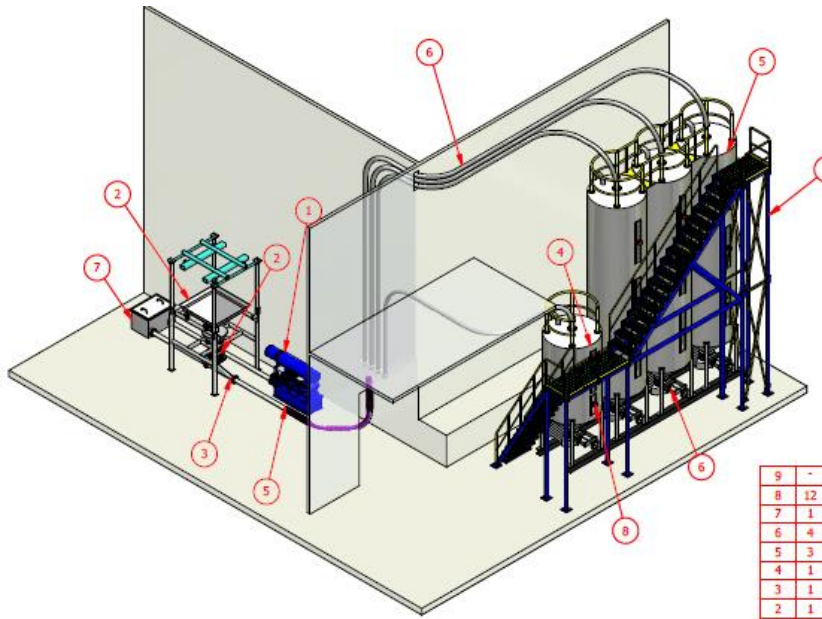

9	-
8	12
7	1
6	4
5	3
4	1
3	1
2	1
1	1

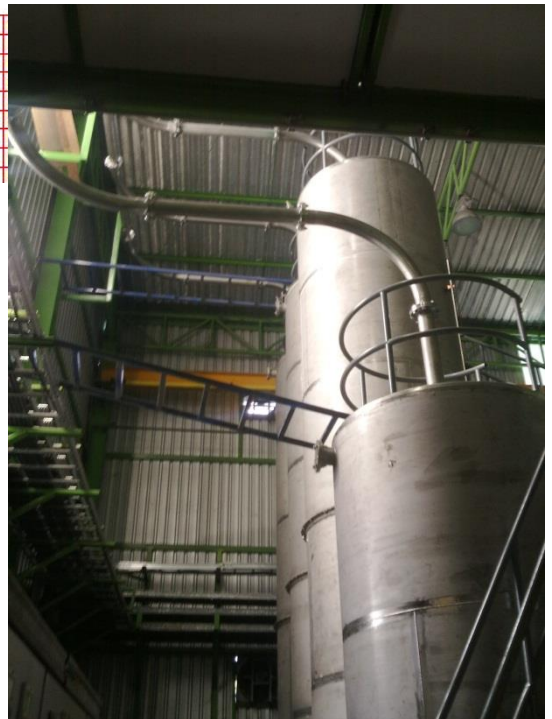

Sea Bulk loading system (PE Pellet) SCG Chem (TPC) Warehouse

The total system consisting of :

- 1 of 7.0 tons Pneumatic conveying systems
- 1 of Big bag unloading stations, fork lift operated, 50 litre hopper
- 1 of High pressure Roots blower 18.5 kw / 25.0 hp
- 1 of Bag filters for dust controlling system, with 1,300 m³ centrifugal fan
- 1 of 4.0 m³ Stainless steel silos
- 3 of 8.0 m³ Stainless steel silos
- 1 of Heavy duty air lock rotary valves (powder valve), Stainless steel 304
- 1 of Electrical control box, with SIEMENS LOGO PLC

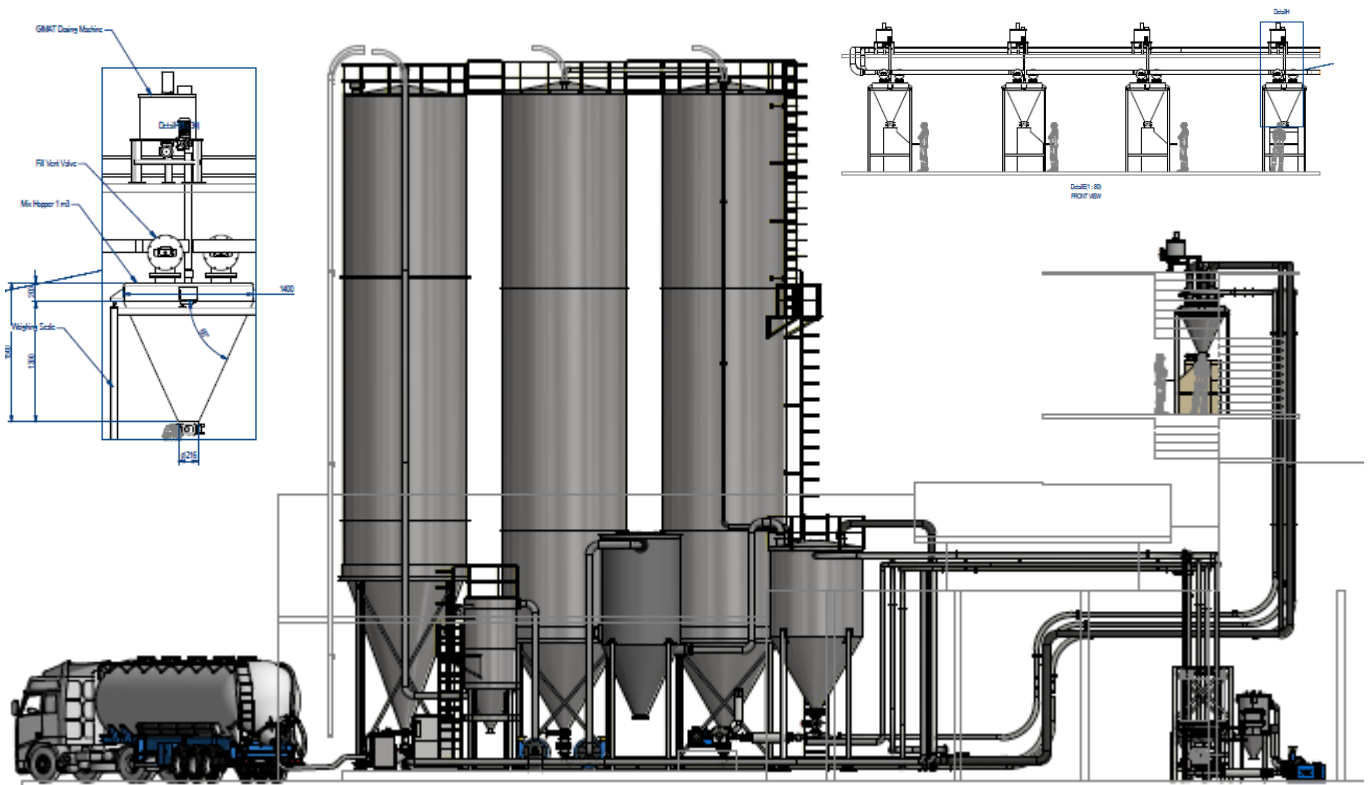

Silos Weighting system (PVC powder & Calcium Carbonate Powder) Saha Area , Twin Lion brand PVC pipe factory



The total system consisting of :

- 3 of 200 m³ (100 tons) Stainless Steel 304 silos
- 1 of 20 m³ (12 tons) Stainless Steel 304 silos
- 4 of 200 tons load cell sets, Thames Sides Sensor , Smart Indicator , Junction box and Low profile mounting load cell assemble set
- 4 of 1.0 m³ (350 kg) Stainless Steel 304 silos
- 4 of 1200 kg load cell sets, Thames Sides Sensor , Smart Indicator , Junction box and Lever mount loadcell weighting assembly
- 12 of Scale valves size 4.0"
- 1 of Electrical control box, with SIEMENS S7 1200

Therec Engineering & Consulting Co., Ltd.

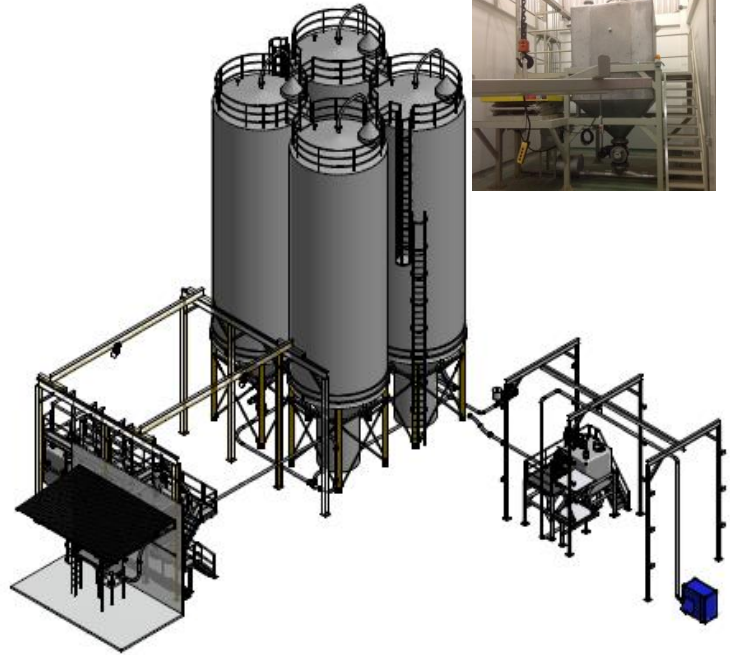

Silos loading system (PE Pellet) CNC International (CPPC group)

The total system consisting of :

- 1 of 5.0 tons Pneumatic conveying systems
- 1 of 1.0 tons Pneumatic conveying systems
- 1 of Big bag unloading stations, 1 rail, 1 hoist operated, 2,000 litre hopper
- 5 of Big bag unloading stations, 1 Overhead Crane operated, 6,000 litre hopper
- 1 of High pressure ring blower 7.5kw / 10.0 hp
- 1 of High pressure roots blower 37.0kw / 50.0 hp
- 1 of Heavy duty air lock rotary valves , Stainless steel 304 , 10.0 inches
- 4 of Medium duty air lock rotary valves , Stainless steel 304 , 6.0 inches
- 4 of 200 m³ (100 tons) J&D Aluminium knock down silos
- 4 of 200 tons load cell set
- 1 of Electrical control box, with SIEMENS LOGO PLC



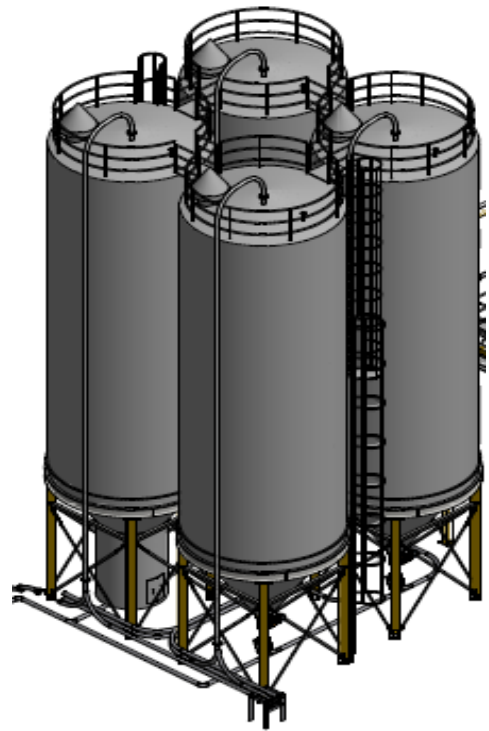

Silos Weighting system (PE Pellet) CNC International (CPPC group)

The total system consisting of :

- 4 of 200 m³ (100 tons) J&D Aluminium knock down silos
- 4 of 200 tons load cell sets, Thames Sides Sensor , Smart Indicator , Junction box and Low profile mounting load cell assemble set
- 1 of Electrical control box, with SIEMENS LOGO PLC



Low profile mounting assembly
Atex & IECEx Certification



Install and Removal
without lifting tool



Silo mount



Smart Digital
Display



Junction box



Therec Engineering & Consulting Co., Ltd.

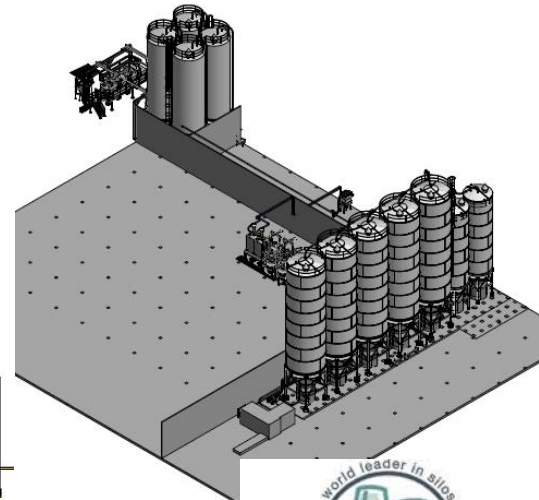

Silos loading system (PP&PE Pellet) Fitesa CNC (CPPC group)

The total system consisting of :

- 2 of 4.5 tons Pneumatic conveying systems
- 2 of Big bag unloading stations, 1 hoist operated, 2,000 litre hopper
- 1 of Big bag unloading stations, 1 hoist operated, 6 ports drop out box
- 2 of High pressure ring blower 15.0kw / 20.0 hp / FPZ
- 8 of Heavy duty air lock rotary valves , Stainless steel 304 , 8.0 inches /TRC
- 11 of Heavy duty air lock diveter valves , Stainless steel 304 , 5.0 inches /DMN
- 5 of 400 m³ (200 tons) J&D Aluminium knock down silos
- 2 of 160 m³ (80 tons) J&D Aluminium knock down silos
- 5 of 200 tons load cell set / Thames side sensor
- 5 of 80 tons load cell set / Thames side sensor
- 1 of Electrical control box, with SIEMENS S7 1200 PLC



Aluminium Silos / Stainless steel Silos / Silo Blender
 Silo feeding / Silo Unloading / Silo Weighting and Leveling

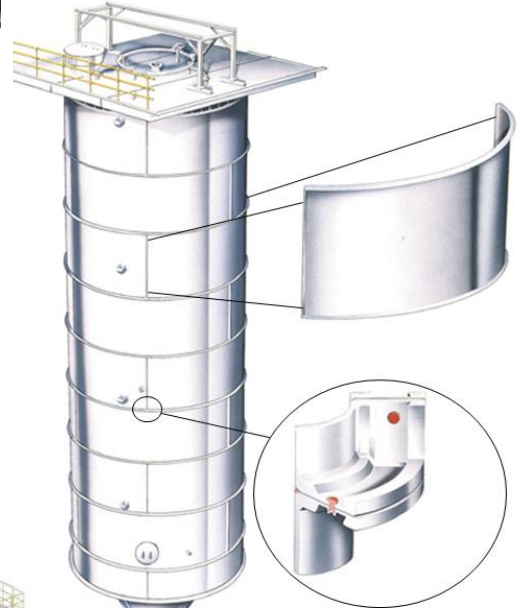
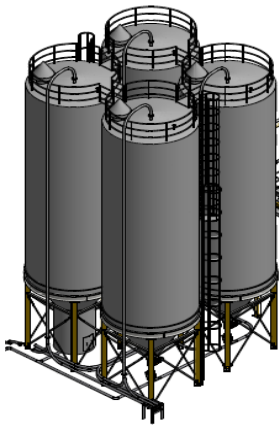

Stainless Steel / Aluminum Silo

STANRIV® SILOS



Silo Blender

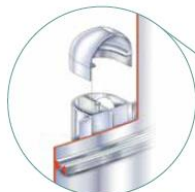

Test blender at J&D Zaandam

Avery gravity blender®



Special Requirement



Therec Engineering & Consulting Co, Ltd. www.thereceng.com
 Tel (662) 893 9003-4 (5 lines) Fax : (662) 893 9005 ,893 9178
 88 Soi Karnjanapisek 4/2 Karnjanapisek Rd. Bangbon Bangkok 10150
 Thailand
 General product Therec 01 / 2021

